

Axle Bearings for Railway Rolling Stock

Spherical Roller Bearings

Spherical roller bearings are self-aligning. Also, they can sustain some axial loads as well as heavy radial loads; hence, the journal box design is relatively simple.



Spherical Roller Bearings

Spherical roller bearings can sustain, not only heavy radial loads, but also some axial loads in either direction. They have excellent radial load carrying capacity and are suitable for use where there are heavy or impact loads.

1. Single spherical roller bearing

The bearing box is allowed to move freely in relation to the axle center because of the self-aligning property of the bearing.

When a single spherical roller bearing is used, the use of a wing-type bearing box is recommended.

2. Two spherical roller bearing

When two spherical roller bearings are used in a double-row configuration, the self-aligning capability of the bearing is lost. But they are provided higher load-carrying capacity.

This type of bearing is used worldwide because of standardized by the International Union of Railways (UIC) in Europe.

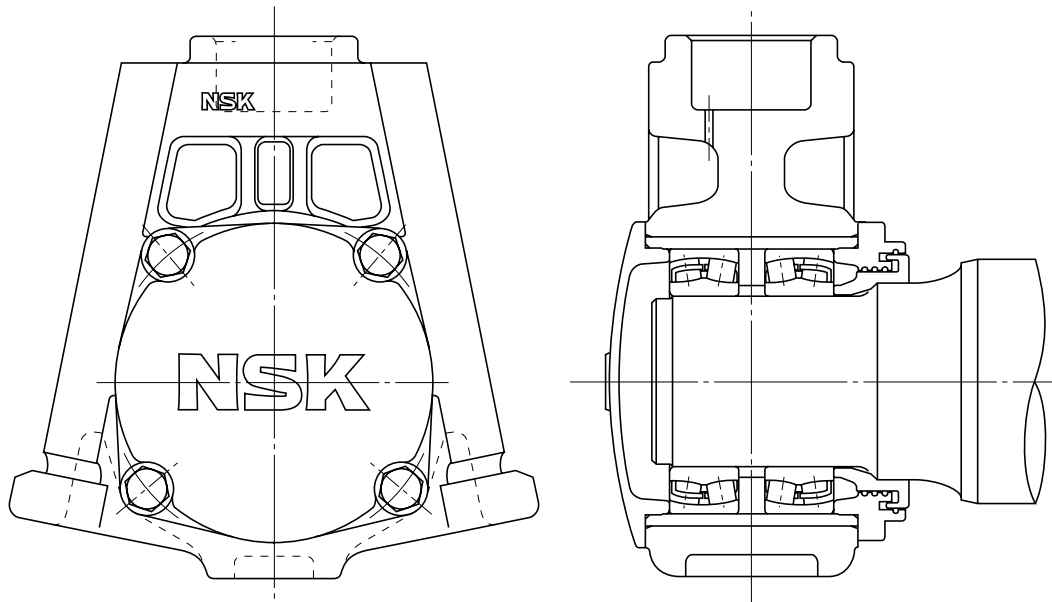

Singapore Mass Rapid Transit Corporation, Subway

Bearing Number: J-232, J-232A

Spherical Roller Bearing Table

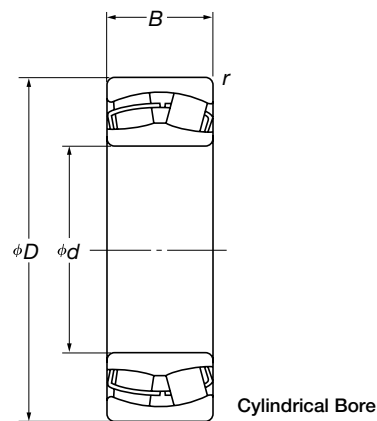

Bearing Numbers	Boundary Dimensions (mm)				Basic Dynamic Load Rating N (lbf)	Basic Static Load Rating N (lbf)
	d	D	B	$r^{(1)}$		
230092C	99.746	180	60.3	3.5	420 000 (94 000)	605 000 (135 000)
23220C	100	180	60.3	2.1	420 000 (94 000)	605 000 (135 000)
23122C	110	180	56	2	385 000 (86 500)	630 000 (141 000)
231255C	119.105	200	62	2 5	465 000 (105 000)	720 000 (162 000)
23124C	120	200	62	2	465 000 (105 000)	720 000 (162 000)
23224C	120	215	76	2.1	630 000 (142 000)	970 000 (218 000)
22324C	120	260	86	3	845 000 (190 000)	1 130 000 (253 000)
23126C	130	210	64	2	505 000 (113 000)	825 000 (186 000)
229750C	130	220	73	2.7 5	575 000 (129 000)	960 000 (216 000)
23226C	130	230	80	3	700 000 (158 000)	1 080 000 (243 000)
22326C	130	280	93	4	995 000 (223 000)	1 350 000 (305 000)
230906C	131.796	220	73	2.7 5	575 000 (129 000)	960 000 (216 000)
228285C	139.734	218	80	1.5 5	605 000 (136 000)	1 040 000 (235 000)
23128C	140	225	68	2.1	580 000 (130 000)	945 000 (212 000)
23228C	140	250	88	3	835 000 (187 000)	1 300 000 (292 000)
231019C	144.475	250	80	2.7 5	725 000 (163 000)	1 180 000 (266 000)
228708C	152.434	250	100	2.7 5	860 000 (193 000)	1 450 000 (325 000)
231481C	157.174	270	86	2 5	855 000 (192 000)	1 400 000 (315 000)
22228M	140	250	68	3	655 000 (147 000)	910 000 (205 000)
23026Ca3	130	200	52	2 5	400 000 (90 000)	655 000 (148 000)
22328	140	300	102	4	1 160 000 (260 000)	1 590 000 (360 000)
23120C	100	165	52	2	345 000 (78 000)	530 000 (119 000)

Note (1) The upper and lower numbers in "r" column refer to radial and axial directions, respectively.